

17  
5

© 1991 BMW AG  
4.95

Nr.	Teile-Nummer	Symbol	Benennung					Bemerkung
				D 150	D 190	D 530	D 636	
1	17 12 1761 119		Seewasserrohr / Sea water pipe / Tube à eau de mer / Havsvattenrör / Tubo acqua di mare		1	1	1	
2	17 12 1761 120		Krümmen / Elbow / Coude / Krök / Gomito		1	1	1	
3	11 53 1326 639		32-50 Schelle / Clamp / Collier / Klämna / Fascetta		14	20	20	
4	17 12 1761 124		Seewasserrohr / Sea water pipe / Tube à eau de mer / Havsvattenrör / Tubo acqua di mare		1	1	1	
5	17 12 1761 125		Krümmen / Elbow / Coude / Krök / Gomito		1	1	1	
6	17 12 1761 122		Schelle / Clamp / Collier / Klämna / Fascetta		2	2	2	
7	07 11 9915 039		6 KTSHR M 6 x 14		1	1	1	
8	17 12 1761 121		Schlauchstutzen / Hose nozzle / Raccord de tuyau / Anslutningsstycke for slang / Raccordo per tubo flessibile		2	2	2	
9	a) 17 12 1761 586		Seewasserrohr / Sea water pipe / Tube à eau de mer / Havsvattenrör / Tubo acqua di mare		1		1	
	a) 17 12 1763 719		dito			1		
10	17 12 1331 113		Ø 29 Rohrschelle / Pipe clamp / Bride de tuyau / Rörklämna / Fascetta di tubo		3	2	4	
11	07 11 9922 087		6 KTMUM 8		2	2	2	
12	17 12 1763 335		1/4" Abflabahn / Drain cock / Robinet de vidange / Utløpskran / Rubinetto di scarico		1	1	1	
13	07 11 9913 483		6 KTSHR M 6 x 25		2	2	2	
14	07 11 9913 624		6 KTSHR M 8 x 16		3	2	3	
15	07 11 9913 815		6 KTSHR M 10 x 16		1	1	1	
16	a) 17 12 1761 585		Seewasserrohr / Sea water pipe / Tube à eau de mer / Havsvattenrör / Tubo acqua di mare		1		1	
17	17 12 1761 588		Halteblech / Retaining plate / Tôle de retenue / Fästplåt / Lamiere di sostegno		1		1	
18	17 12 1761 583		Krümmen / Elbow / Coude / Krök / Gomito		1	1	1	
19	17 12 1761 584		dito		1		1	
20	17 12 1761 589		Haltewinkel / Support angle / Corniere d'appui / Winkelstöd		2	2	2	

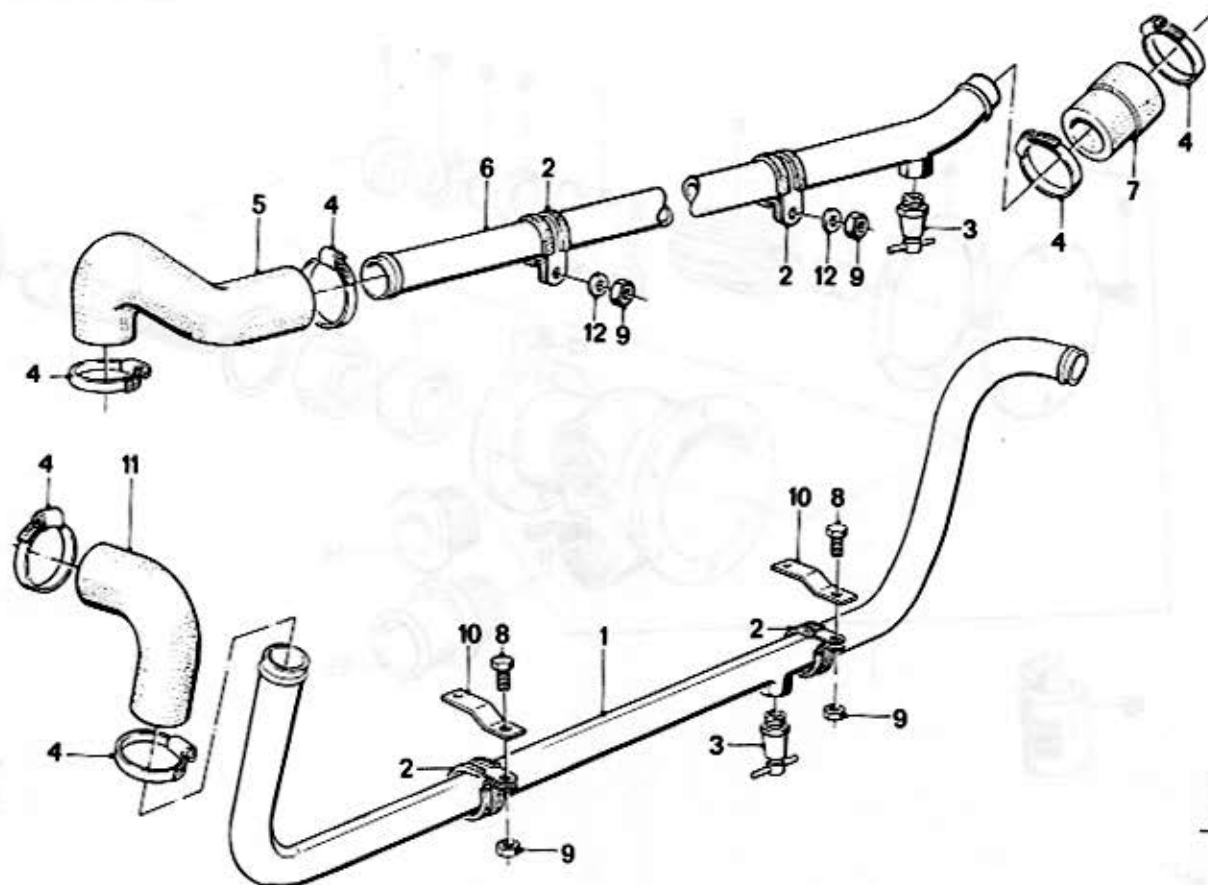

**17**  
**6**

D 530/536  
4/86

17 6		4/86								
Nr.	Teile-Nummer	Symbol	Benennung	D 150	D 190	D 530	D 636	Bemerkung		
1	a 17 12 1763 504		Seewasserrohr / Sea water pipe / Tube à eau de mer / Havsvattenrör / Tubo acqua di mare				1			
	a 17 12 1763 810		dito			1				
2	17 12 1331 113		∅ 29 Rohrschelle / Pipe clamp / Bride de tuyau / Rörklämma / Fascetta di tubo			4	4			
3	17 12 1763 335		1/4" Ablasshahn / Drain cock / Robinet de vidange / Utloppskran / Rubinetto di scarico			2	2			
4	1153 1326 639		32-50 Schelle / Clamp / Collier / Klämme / Fascetta			6	6			
5	17 12 1763 230		Krümmen / Elbow / Coude / Krök / Gomito			1	1			
6	17 12 1763 229		Seewasserrohr / Sea water pipe / Tube à eau de mer / Havsvattenrör / Tubo acqua di mare			1	1			
	17 12 1763 722		dito			1				
7	17 12 1763 231		Schlauchstutzen / Hose nozzle / Raccord de tuyau / Anschlussstück für slang / Raccordo per tubo flessibile			1	1			
8	07 119913 624		6 KT SHR M 8 × 16				2			
9	07 119922 087		6 KT MU M 8				2			
10	17 12 1761 589		Haltewinkel / Support angle / Corniere d'appui / Winkelstöd / Squadra de sostegno			2	2			
11	17 12 1761 583		Krümmen / Elbow / Coude / Krök / Gomito			1	1			
12	07 119931 067		8,4 Scheibe / Washer / Rondelle / Bricks / Rondella				2	2		