

11
17
D 7
12/87

11 17		12/87			D 7	D 12	Bemerkung
Nr.	Teile-Nummer	Symbol	Benennung				
1	11 62 1 763 094		Abgassammler / Exhaust plenum chamber / Collecteur d'échappement / Avgassamlare		1		
2	11 62 1 329 005		Dichtung / Seal / Garniture / Packning		1	1	
3	a 07 11 9912 556		6 KT SHR M 8 × 80		2	2	
	07 11 9912 506		6 KT SHR M 8 × 45		4	4	
4	07 11 9913 657		6 KT SHR M 8 × 25		2	2	
5	a 17 12 1 329 241		Rohrleitung / Pipeline / Conduit dj tuyau / Rörledning		1		
6	a 17 12 1 329 245		Anschlußstück / Connecting piece / Pièce de raccordement / Kopplingsstycke		1		
7	07 11 9963 290		Dichtring / Gasket ring / Anneau de garniture / Packning		1		
8	07 11 9919 193		VSL-SHR		1		
9	07 11 9963 201		Dichtring / Gasket ring / Anneau de garniture / Packning		1		
10	11 12 1 763 261		VSL-SHR		1		

a) ist in Verbindung mit Abgassammler 11 62 1 329 013 / in connection with exhaust plenum chamber 11 62 1 329 013 / en connexion avec collecteur d'échappement 11 62 1 329 013 / in samband med Avgassamlare 11 62 1 329 013

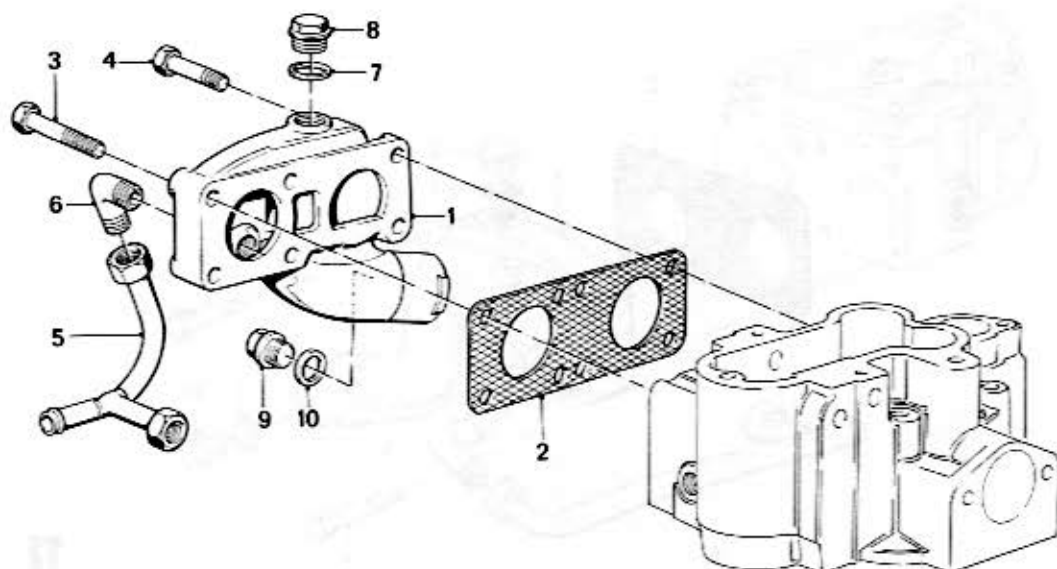

11
18
D12
12/87

11 18		12/87			D7	D12	Bemerkung
Nr.	Teile-Nummer	Symbol	Benennung				
1	11 62 1 763 096		Abgassammler / Exhaust plenum chamber / Collecteur d'échappement / Avgassamlare			1	
2	11 62 1 329 005		Dichtung / Seal / Garniture / Packning		1	1	
3	a 07 11 99 12 506 07 11 99 13 657		6 KT SHR M 8 x 45 6 KT SHR M 8 x 25		4	4	
4	a 07 11 99 13 657 07 11 99 12 506		6 KT SHR M 8 x 25 6 KT SHR M 8 x 45		2	2	
5	17 12 1 329 243		Rohrleitung / Pipeline / Conduit d)tuyau / Rörledning			1	
6	17 12 1 329 245		Anschlußstück / Connecting piece / Pièce de raccordement / Kopplingsstycke			1	
7	07 11 99 63 290		Dichtring / Gasket ring / Anneau de garniture / Packning			1	
8	07 11 99 19 193		VSL SHR			1	
9	11 12 1 763 261		VSL SHR			1	
10	07 11 99 63 201		Dichtring / Gasket ring / Anneau de garniture / Packning			1	

a) Nur in Verbindung mit 11 62 1 329 001 / Only in connection with 11 62 1 329 001 / Seulement en connexion avec 11 62 1 329 001 / Endast in samband med 11 62 1 329 001